

## Product datasheet

# KREBS® hMAX pumps for Water Treatment applications

Shearing and degradation can wreak havoc on your water treatment operations. Air locking and pump wear lead to unplanned shutdowns and high maintenance costs. Our hMAX pump addresses all these challenges and more, making it ideal for even the toughest industrial applications.

We understand that water treatment processes vary widely, so we provide options that allow you to customise your pump for your specific needs. Our pump experts help customers like you navigate the optional features so you are certain that you get the best pump for your process.

- Available in sizes 80×50—250×200 mm
- (3×2 to 10×8 in)
- All industry standard shaft seal arrangements available
- All typical industry pump and motor arrangements available
- Vertical cantilever arrangement (vMAX™) are available and no shaft seal needed

### Benefits

- Minimised product degradation and shearing
- Pumps large fibrous materials
- Extended wear life

### Common applications

- Grit transfer
- Digester recirculation
- Large solids handling

# Our technology hard at work for you

We designed our hMAX to handle large, shear sensitive solids without clogging or degrading the product. Its recessed impeller and large internal clearances make it uniquely suited to process the tramp materials that are common in the water treatment industry.

The technology allows even large solids to pass through the pump without touching the impeller. Whether you encounter large chunks of hard plastics and metals or long, stringy substances or both, our pump is made to handle it. Almost anything that can fit to pass through the discharge will successfully make it through the pump, allowing you to forget your worry about clogs.

Unlike most centrifugal pumps, the hMAX operates without radial loads thanks to our heavy-duty concentric casing design. The reduction of pressure results in a longer life for the pump, seals and bearings. From the highest to the lowest flows, our pump is up to the task. These are just a few of the features that the hMAX pump offers to water treatment applications.

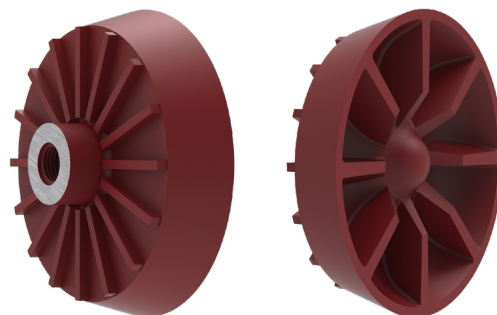

- Special impeller vane design for eliminating ragging issues
- Back impeller vanes to keep grit away from the shaft seal
- Impeller recessed design has a low rate of wear
- Impeller, suction liner and casing are 28% High-Chrome steel with a minimum 650 BHN

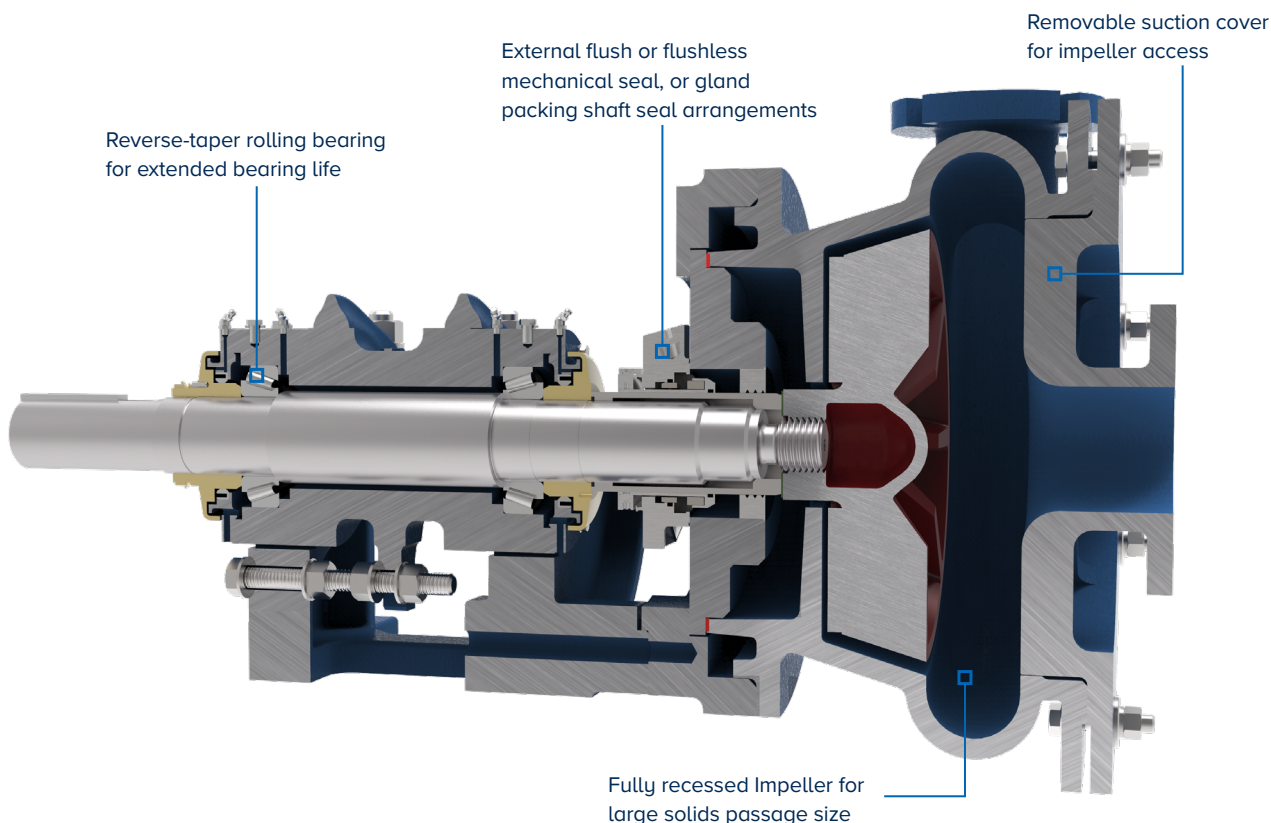

**FLSmidth A/S**  
2500 Valby  
Denmark  
Tel. +45 3618 1000  
info@flsmidth.com

[www.flsmidth.com](http://www.flsmidth.com)

**FLSmidth Inc.**  
Tucson Operations  
Tucson, AZ 85743  
USA  
Tel + 1 520 744 8200  
krebs@flsmidth.com

Copyright © 2023 FLSmidth A/S. All Rights Reserved. FLSmidth and FLS are (registered) trademarks of FLSmidth A/S. This brochure makes no offers, representations or warranties (express or implied), and information and data contained in this brochure are for general reference only and may change at any time.